

An Elimination Method of the Nonlinear Distortion in Frequency Domain by the Volterra Filter.

Yasuo Nomura and Yoshinobu Kajikawa

Department of Electronics, Faculty of Engineering, Kansai University,
3-3-35, Yamate-cho, Suita-shi, Osaka 564, Japan
nomura@joho.densi.kansai-u.ac.jp

ABSTRACT

There are two types of distortion of the loudspeaker system, the linear and the nonlinear distortions. We have tried to eliminate the linear distortion by digital filters. However, the more quantity of the elimination of the linear distortion, results in the more quantity of the nonlinear distortion. Therefore in order to make a high quality audio system we need to eliminate both the linear and the nonlinear distortions at the same time. First, we have identified the loudspeaker system by the Volterra expansion which expresses the relationship between input and output signals, and then proposed the design method of the inverse system. The result of simulation shows that a decrease of the nonlinear distortion of about 100dB can be obtained by using the design method proposed here.

1. Introduction

The loudspeaker is a very complex system which converts an electric signal into the mechanical vibration and outputs the acoustic signal. However, distortions occur in the generates signal because the structure is complex. When the system doesn't satisfy the distortionless condition, we call that the system has 'linear distortion'. When the output waveform is not proportional to its input waveform, we call that the system has 'nonlinear distortion'. A nonlinear distortion can be classified further: A case where a single sinusoidal wave input produces higher harmonics at its output; and a case where two sinusoidal waves inputs produce an intermodulation components (one having the sum of frequencies of the two inputs, and another one having the difference of frequencies of the two inputs).

Up to now, the studies on elimination methods of the linear distortion by the linear digital signal processing have been done as a method of making high quality of loudspeaker system [1]. However, the nonlinear distortion increases with eliminating the linear distortion. Therefore, to make high quality of the loudspeaker system, it is necessary to eliminate not only the linear distortion but also the nonlinear distortion at the same time. Recently, the Volterra series expansion [2] has been applied successfully to the analysis, design and identify of nonlinear systems [3-9]. In [7-9], nonlinear distortions in loudspeakers are reduced using Volterra filter. The design schemes of [7-9] are

based on the time domain approach. In this paper, we propose the method eliminating a nonlinear distortion with the Volterra filter [10],[11]. In this method, the loudspeaker system is identified by using various characteristics of the Volterra series in the frequency domain. The proposed method is applied to an actual loudspeaker system. As a result, we clarify to be unable to disregard the nonlinear output compared with the linear output in a low frequency region. Therefore, it is understood that the nonlinear distortion elimination of the loudspeaker system is important. In addition, we propose the design method of the Volterra filter which eliminates linear and nonlinear distortions at the same time. It is shown that the output level of a nonlinear distortion can be decreased by about 100dB by this method.

2. The Volterra Series Expansion

Now, a discrete -time, time-invariant, and causal nonlinear system with memory can be expressed by means of an extension of the following Volterra series expansion [2].

$$y(n) = \sum_{k_1=0}^{N-1} h_1(k_1)x(n-k_1) + \sum_{k_1=0}^{N-1} \sum_{k_2=0}^{N-1} h_2(k_1, k_2)x(n-k_1)x(n-k_2) \quad (1)$$

where $x(n)$ and $y(n)$ represent the input and output signals respectively and $h_1(k_1)$ and $h_2(k_1, k_2)$ are the first- and second-order Volterra kernels of the system respectively. The M points discrete Fourier transform (DFT) of eq. (1) is

$$Y(m) = H_1(m)X(m) + A^1[H_2(m_1, m_2)X(m_1)X(m_2)] \quad (2)$$

where $X(m)$, $Y(m)$, $H_1(m)$, and $H_2(m_1, m_2)$ are the M points DFTs of $x(n)$, $y(n)$, $h_1(k_1)$, and $h_2(k_1, k_2)$ respectively. In (2), $H_1(m)$ and $H_2(m_1, m_2)$ will be called the first- and second-order Volterra frequency response (VFR) for convenience in this paper and A^1 is called the first-order reduction operator and maps the function with the two-dimensional dependent variables to that with the one-dimensional one.

3. The First-Order Reduction

The first-order reduction operator maps the function with the two-dimensional dependent variables to that with the one-dimensional one as

$$Y_2(m) = A^1[Y_2'(m_1, m_2)] = \frac{1}{M} \sum_{m_1+m_2=(m+rM)} Y_2'(m_1, m_2) \quad (3)$$

where $Y_2(m)$ and $Y_2'(m_1, m_2)$ are the functions with one- and two-dimensional dependent variables, and $r=0,1$. Fig. 1 shows the state of first-order reduction.

It is found from Fig. 1 that the second-order output $Y_2(p)$ at frequency p is obtained by summing up the values of $Y_2'(m_1, m_2)$ for $m_1+m_2=p+rM$, $r=0,1$. It is also found from Fig. 1 that the conventional sampling theorem cannot be applied because the maximum frequency of the output become more than $2\omega_{\max}$ (which is the maximum frequency of the input). Consequently, the Volterra sampling theorem is applied in this case.

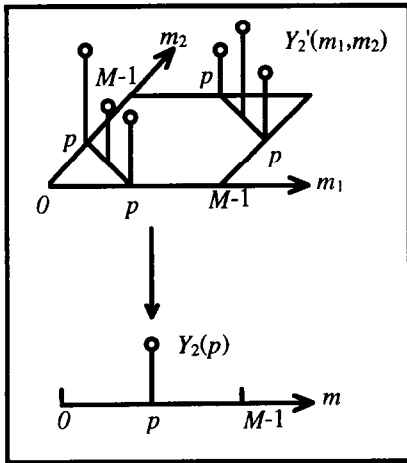

Fig. 1 The concept of first-order reduction

4. The Volterra Sampling Theorem

The Volterra sampling theorem is defined as,

“The input signal $x(n)$ or/and the second-order Volterra kernel $h_2(k_1, k_2)$ must be limited to frequency band which is less than quarter the sampling frequency.”

When the signal x which is a bandlimited signal with maximum frequency component ω_{\max} is input the system defined as Eq.(2), the bandlimited second-order nonlinear signal with maximum frequency component $2\omega_{\max}$ is output. If ω_{\max} and the maximum frequency of second-order Volterra kernel are over $\pi/2$, the maximum frequency of output signal become over π and the output contains aliasing components. Therefore, the input signal and/or the second-order Volterra kernel must be bandlimited with

less $\pi/2$.

5. The Needed Area of VFR

Let us consider some properties of the second-order VFR. The minimum area needed to complete the second-order VFR can be derived from some properties of the second-order VFR. We explain each needed area derived from each property of the second-order VFR in order to derive the minimum area.

First of all, from the property that the second-order VFR is symmetric as shown in the following expression, the second-order VFR needs the hatched area in Fig. 2 (a).

$$H_2(m_1, m_2) = H_2(m_2, m_1). \quad (4)$$

Since the Volterra sampling theorem extended from the conventional sampling theorem applies to the nonlinear systems, the second-order VFR needs the hatched area in Fig. 2 (b). Next, since the second-order Volterra kernel is generally a real number, the second-order VFR is conjugate symmetric.

$$h(k_1, k_2) \in R \xrightarrow{M \text{ point DFT}} H(m_1, m_2) \Rightarrow H(m_1, m_2) = H^*(M - m_1, M - m_2) \quad (5)$$

Therefore, the second-order VFR needs the hatched area in Fig. 2 (c). Finally, the hatched area in Fig. 2 (d) is needed in order to complete the second-order VFR from the above properties. Consequently, since the number of the processing points which need to model and design the second-order VFR in practice decreases to $M^2/16$ from Fig. 2 (d).

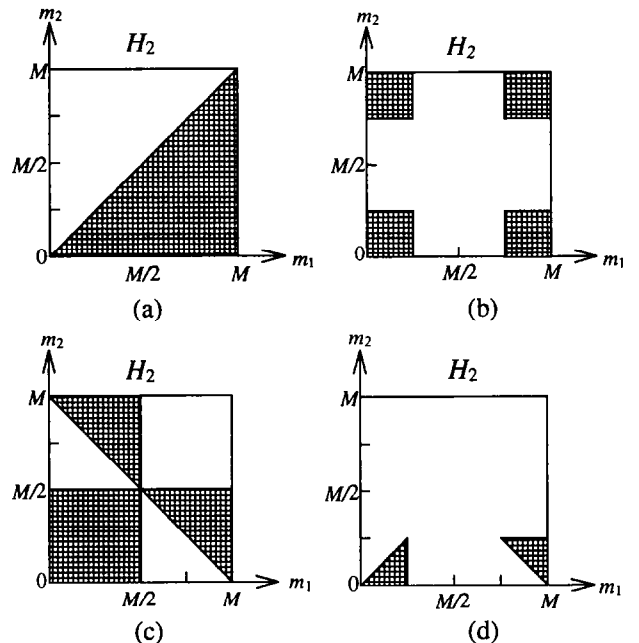

Fig. 2 The needed area of H_2 derived from the property of VFR.

6. The Identification Method of VFR

The identification of the second-order VFR is performed by using the following equation.

$$H_2(m_1, m_2) = \begin{cases} \frac{Y(m_1 + m_2)}{2X(m_1)X(m_2)} [m_1 \neq m_2] \\ \frac{Y(m_1 + m_2)}{X(m_1)X(m_2)} [m_1 = m_2] \end{cases} \quad (6)$$

where m_1 and m_2 are frequencies of an input signal. Consequently, the identification of the nonlinear system is achieved by calculating Eq. (5) for various sets of two frequencies. However, the value of second-order VFR for $m_1=2m_2$ cannot be obtained. This is because the frequencies of the linear output for m_2 and the nonlinear output for m_1-m_2 are the same. To solve this problem, we decide the value of second-order VFR for $m_1=2m_2$ by averaging the values of the second-order VFR at the near frequencies.

Fig. 3 shows an automatic system measuring second-order VFR of loudspeaker system by using the above theorem. The computer generates two sinusoidal waves and transmits those data to the FFT analyzer by GPIB standard. LPF is used for smoothing the output waves of FFT analyzer. The output signal is transmitted to the A channel of FFT analyzer and the audio amplifier. In addition, the output signal of audio amplifier is transmitted to the loudspeaker system. The output is transmitted to the B channel of FFT analyzer through the microphone. The transfer function between A and B channels is calculated and transmitted to the computer. The computer controls the above operation.

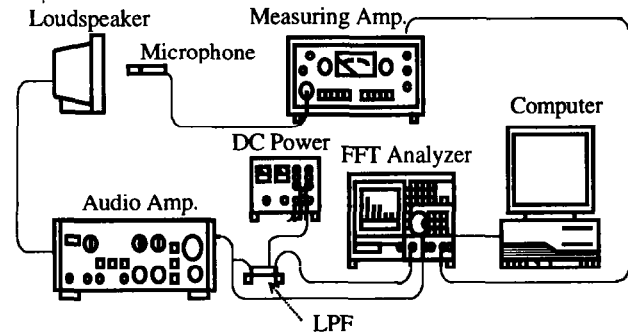

Fig. 3 Automatic measuring system of second-order VFR.

The practical result of identifying the second-order VFR of a loudspeaker by the proposed method is shown in Fig.4. In this figure, the points for $m_1=m_2$ show the second-order harmonic distortion and the points for $m_1 \neq m_2$ shows the second-order intermodulation distortion. It is found from Fig. 4 that the second-order nonlinear distortion cannot be disregarded compared with the linear output in a low frequency region.

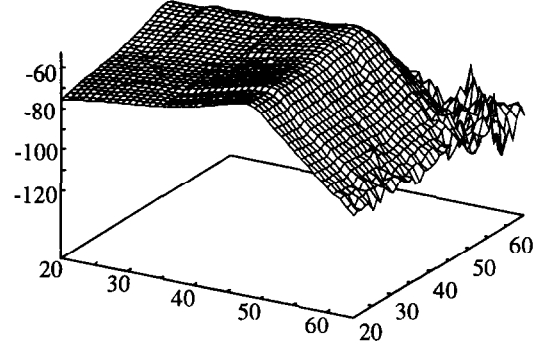

Fig. 4 The second-order distortion level of the loudspeaker system.

7. The Design Method of the Nonlinear Inverse System in the Frequency Domain

The nonlinear inverse system is arranged in the former part of the unknown nonlinear system as shown in Fig. 5. In Fig. 5, the first- and second-order Volterra filters, H_1 and H_2 , eliminate the linear and second-order nonlinear distortion respectively. H_1 and H_2 are designed by the following procedures.

- 1) H_1 is designed as the linear inverse system of D_1 . That is, H_1 is designed so that the amplitude and phase characteristics can satisfy the condition of no distortion;
- 2) H_2 is designed that the second-order nonlinear output signals from D_2 and H_1 , and from D_1 and H_2 can be canceled each other.

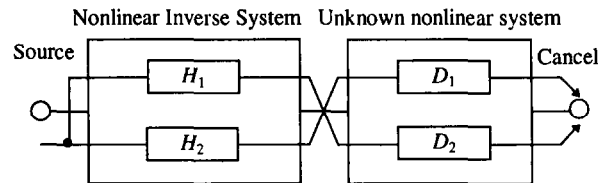

Fig. 5 The block diagram of tandem connection of the nonlinear inverse system and the unknown nonlinear system.

Here, we derive the designing method of H_2 by considering the flow of signals of procedure 2 in the frequency domain. From the condition that two second-order nonlinear output signals in Fig. 5 are canceled each other, the following equation is derived.

$$\mathbf{A}^1 [D_2(m_1, m_2)H_1(m_1)X(m_1)H_1(m_2)X(m_2)] = -D_1(m)\mathbf{A}^1 [H_2(m_1, m_2)X(m_1)X(m_2)] \quad (6)$$

In addition, putting $D_1(m)$ on the right side in the reduction operator, and by removing the reduction operator we obtain

$$H_2(m_1, m_2) = -\frac{D_2(m_1, m_2)H_1(m_1)H_1(m_2)}{D_1(m_1 + m_2)} \quad (7)$$

Finally, the following equation is derived from the relations that $D_1(m_1+m_2)=D_1(m_1)+D_1(m_2)$ and $H_1=D_1^{-1}$.

$$H_2(m_1, m_2) = -H_1(m_1)H_1(m_2)D_2(m_1, m_2)H_1(m_1)H_1(m_2) \quad (8)$$

Hence, we can design the second-order VFR of the nonlinear inverse system H_2 by using eq. (8).

8. An Example and Result

We present an application example to a loudspeaker. Fig. 6 shows the second-order Volterra filter designed by proposed method. Next, to estimate whether the nonlinear inverse system designed by the above procedures can eliminate the second-order nonlinear distortion enough, Fig. 7 shows the levels of the second-order nonlinear distortion in the system of Fig. 5. It is clear from comparison between Fig. 4 and Fig. 7 that the second-order nonlinear distortion is eliminated enough (the maximum elimination level is about 100dB). Consequently, it is found that the proposal design method of the nonlinear inverse system is very effective to eliminate the linear and nonlinear distortions.

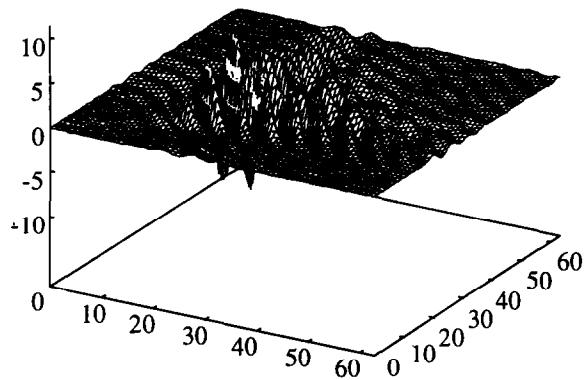

Fig. 6 The second-order Volterra filter designed by proposed method.

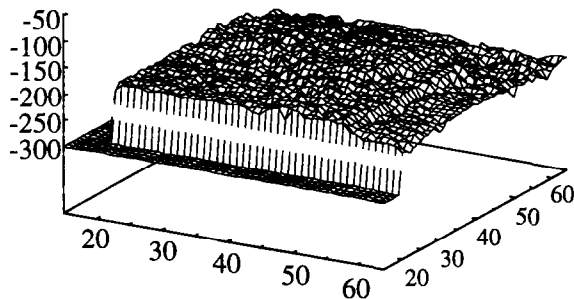

Fig. 7 The second-order distortion level of the tandem connection system of the loudspeaker system and the corresponding nonlinear inverse system.

9. Conclusion

This paper proposes the method identifying the second-order VFR of loudspeaker system by using various characteristics of the Volterra series, and clarifies the characteristic of the second-order VFR. In addition, proposes the method designing the Volterra filter which eliminates the linear and nonlinear distortions at the same time. An example shows that the proposed method can eliminate linear distortions with reduction of the secondary nonlinear distortion even by 100 dB. This shows that the proposed method is effective. Further reduction of computation time of the identification method is subject to study in the future.

REFERENCES

- [1] Kuriyama, "Adaptive loudspeaker system," J. Audio Eng. Soc. vol. 37, no. 11, pp. 919-929, Nov. 1989.
- [2] Schetzen, *The Volterra and Wiener theories of nonlinear systems*, Kriger, Florida, 1989.
- [3] M. J. Smith, C. F. N. Cowan, and P. F. Adams, "Nonlinear echo cancellers based on transpose distributed arithmetic," *IEEE Trans. Circuits & Syst.*, vol. CAS-35, no. 1, pp. 6-18, Jan. 1988.
- [4] M. J. Coker and D. N. Simkins, "A nonlinear adaptive noise canceller," *Proc. 1980 Int. Conf. Acoust., Speech & Signal Process.* pp. 470-473, Apr. 1980.
- [5] J. C. Stapleton and S. C. Bass, "Adaptive noise cancellation for a class of nonlinear, dynamic reference channels," *IEEE Trans. Circuits & Syst.*, vol. CAS-32, no. 2, pp. 143-150, Feb. 1985.
- [6] V. J. Mathews, "Adaptive polynomial Filters", *IEEE SP Magazine*, vol. 8, no. 3, pp. 10-26, Jul. 1991.
- [7] W. Frank, R. Reger, and U. Appel, "Loudspeaker nonlinearities - Analysis and compensation", *Conf. Record 26th Asilomar Conf. On Signals, Systems and Computers*, Pacific Grove, CA, pp. 756-760, Oct. 1992.
- [8] W. Frank, R. Reger, and U. Appel, "Realtime loudspeaker linearization", *IEEE Winter Workshop on Nonlinear Digital Signal Processing*, Tampere, Finland, 2.1-3, Jan. 1993.
- [9] W. A. Frank, "An efficient approximation to the quadratic Volterra filter and its application in real-time loudspeaker linearization", *Signal Processing*, vol. 45, pp. 97-113, 1995.
- [10] T. Ishikawa, K. Nakashima, Y. Kajikawa, and Y. Nomura, "A study on the elimination of nonlinear distortion of an audio system by the Volterra filter", *Technical Report of IEICE*, E94-89, Jan. 1995. [in Japanese]
- [11] T. Ishikawa, K. Nakashima, Y. Kajikawa, and Y. Nomura, "A consideration on elimination of nonlinear distortion of the loudspeaker system by using digital Volterra filter", *IEICE Trans.*, vol. J79-A, no. 7, pp. 1236-1243, Jul. 1996. [in Japanese]